

Series 0401A
STATIONARY INFLATABLE TRUCK SHELTER
INSTALLATION INSTRUCTIONS
STEEL FRAME

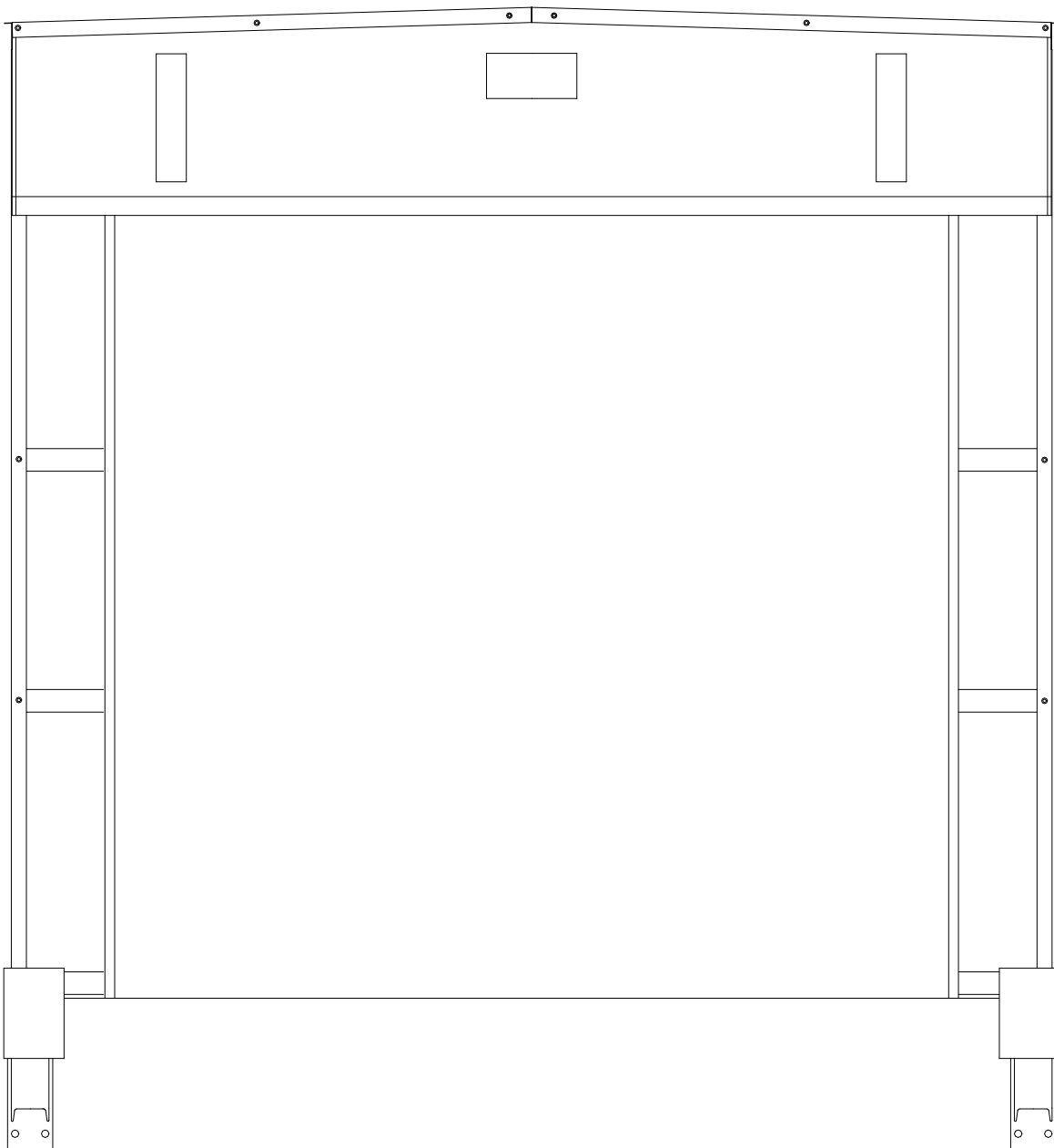

Series 0401A – STATIONARY INFLATABLE TRUCK SHELTER

INSTALLATION LISTS

THE FOLLOWING LISTS COVER BASIC INSTALLATION, NOT INCLUDING OPTIONS

Components List (per Panel)

No.		Qty.
1	Vertical Frames c/w Air Bags	2
2	Head Frame c/w Header Air Bag Assembly	1
3	Protective Guards	2
4	Vertical Storage Curtains	2
5	Head Storage Curtain	1
6	Motor/Blower	1

Hardware Supplied List (per Panel)

No.		Qty.
7	3/8" Sleeve Anchor Bolts	9
8	3-Hole Mounting Brackets	9
9	4-Hole Mounting Brackets	2
10	10" Vertical Curtain Support Strap	2
11	Hose Clamps 3 1/2"	4
12	On/Off Switch	1
13	1/4" x 1-1/2" Self-drilling Screws	48
14	3/8" Washers	48
15	#10 x 3/4" Self-drilling Screws	16
16	1/4" Washers	16
17	Flexible Ducting	2
18	Hose Clamp 3 1/2" – 5 1/2"	1
19	1/8" Bungee cords 30" Long	2
20	Installation Instructions	1

Recommended Tools List

Qty.		Qty.	
1	Tape Measure	1	5/16" Masonry Drill Bit
1	Plumb Line or Level	1	Hammer
1	Pencil or Marker	1	#2 Robertson Screwdriver
1	Square	1	#1 Robertson Screwdriver
1	Power Drill	2	1/2" Wrench
1	3/8" Hex Head Driver Bit	3	Flat 2 x 4 supports
1	7/32" HSS Drill Bit		Caulking
1	Hammer Drill		

Series 0401A – STATIONARY INFLATABLE TRUCK SHELTER

INSTALLATION INSTRUCTIONS

READ ALL INSTRUCTIONS BEFORE INSTALLING SHELTER. SUPER SEAL MFG. LTD. WILL NOT BE HELD RESPONSIBLE FOR IMPROPER INSTALLATION OF ANCHORING DEVICES, OR FOR INSTALLATION INTO AGED OR UNSOUND CONCRETE, CONCRETE BLOCK, OR OTHER WALL OR FLOOR MATERIAL WHICH MAY RESULT IN PREMATURE PRODUCT WEAR, PRODUCT FAILURE, PROPERTY DAMAGE, OR PERSONAL INJURY.

1. Check Order

- a. **Measure door opening height and width.** Make sure dimensions match the Purchase Order.

Make sure there is enough space to install shelter (Figure 1a).

- * Check for existing:
 - dock seals
 - bollards or obstacles
 - lights and conduit
 - drains.

NOTE: MAKE SURE ENOUGH SPACE EXISTS BETWEEN THE DOOR OPENING AND THE FRAMES TO INSTALL MOUNTING BRACKETS INSIDE THE SHELTER.

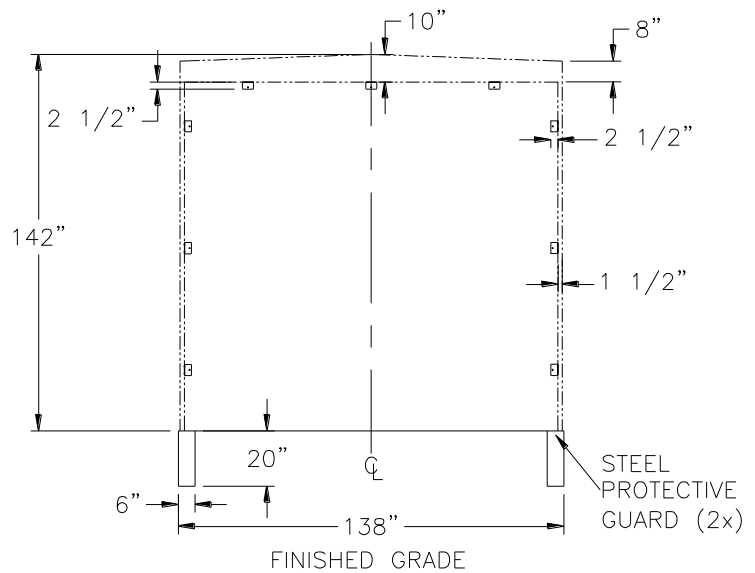

- * If there is not enough space, install the Mounting Brackets on the outside of the Frames (Figure 1b).

Standard units are designed for a 48" dock height, level approach.

- b. **Check Components and Hardware Supplied List.** Make sure all components and hardware are present.
- c. **Check Recommended Tools List.** Make sure all recommended tools are available.
- d. **Determine method of mounting door to wall.**

Super Seal supplies 3/8" x 1-7/8" expansion anchors with the shelter.

The customer must supply any other mounting hardware, including that for Steel Protective Guards.

Concrete Block, Precast Concrete, or Brick wall: Use supplied expansion anchors. If anchors will not hold, use 3/8" threaded rod for through-bolt fastening.

Metal Siding: Use 3/8" threaded rod for through-bolt fastening with steel or wood backup plate.

- **WELDING THE SHELTER TO THE WALL IS NOT RECOMMENDED.**

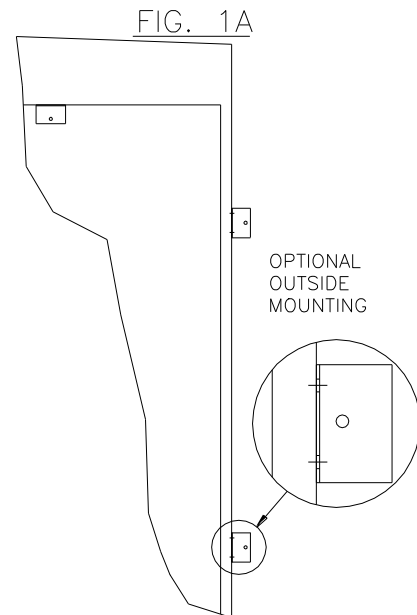

FIG. 1B

2. Prepare Dock Door Opening

- a. **Measure and mark center** of dock door opening (Figure 2).

Mark centerline on dock floor.

Mark centerline on lintel above door.

* Extend line to 148" above dock floor.

Make sure marks are plumb to each other.

- b. **Draw a level line** even with the dock floor along both sides of dock face.
- c. **Measure Head Frame width** and divide by 2.
- d. **Mark Vertical Frame positions.**

Measure 1/2 the Head Frame width from dock floor centerline to one side of level line.

Mark.

Repeat for other side.

3. Mount Steel Guards

- a. **Position Guard.**

Determine left and right Guards. Place welded bracket on outside (Figure 3).

Place top flat surface of Guard along level line.

Place outside edge of Guard 5/8" outside Vertical Frame mark.

- b. **Guard must be perpendicular to building wall,** Make sure Guard is **level and square.**
Shim, if necessary.

- c. **Bolt Guard to wall.**

Recommend using 5/8" x 3-1/2" wedge anchor bolts or appropriate mounting hardware (not supplied).

- d. **Repeat** for other side.

- e. **Make sure left and right** Guards are **level to each other.**

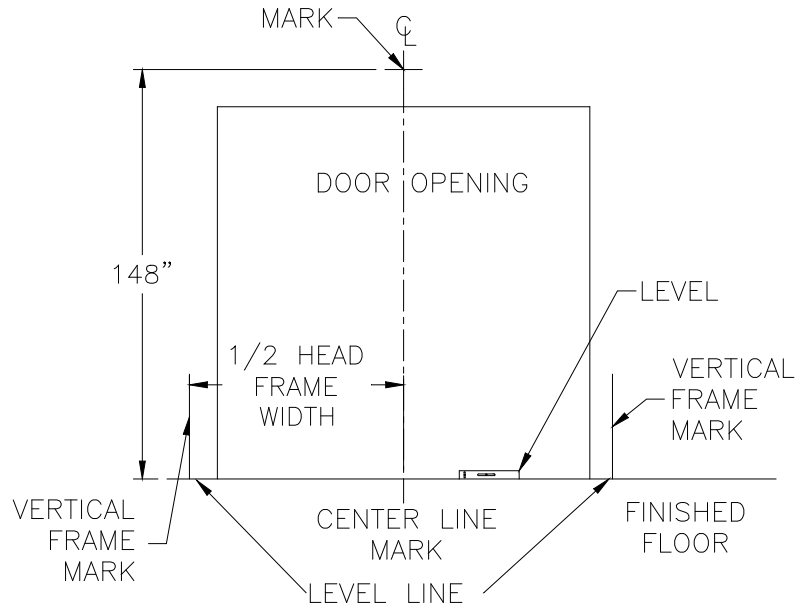

FIG. 2

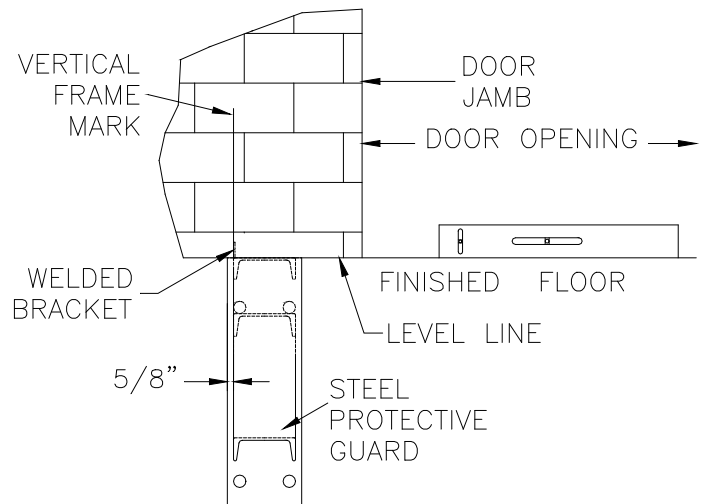

FIG. 3

4. Attach Mounting Brackets to Vertical Frames

NOTE: IF STATIONARY VERTICAL 0401 PANELS IN LIEU OF AIR BAGS OR STATIONARY VERTICAL SUPERSNUG PANELS IN LIEU OF AIR BAGS ORDERED, PLEASE SUBSTITUTE STEPS 4, 5, 6, 13, AND 14 WITH OPTIONS INSTRUCTIONS, STEPS O1, O2, AND O3.

a. **Position Vertical Frames.**

Determine left and right Vertical Frames.

- * Air Duct is at the top front of each Vertical Frame (Figure 4).
- * STOP should appear on the bottom outside of the RIGHT Air Bag.

Place Vertical Frames on clean, flat 2 x 4 supports.

- * Place siding face down, wall edges to inside.

NOTE: DO NOT PUNCTURE AIR BAG OR SCRATCH SIDING.

b. **Position Mounting Brackets** on Vertical Frame (Figure 4).

Use three (3) 3-hole Mounting Brackets per Vertical Frame.

Measure 12" in from top and bottom of Vertical Frame on wall edge.

Position top and bottom Mounting Brackets inside of 12" mark.

- * Place **along wall side**, angle flush to edge.

Position middle Mounting Bracket in center.

c. **Attach Mounting Brackets** to Vertical Frame with 1-1/2" self-drilling screws.

d. **Position 4-hole Angle Bracket** on Vertical Frame (Figure 4).

Position 4-hole Mounting Bracket on bottom of top cross-member.

- * Place the Mounting Bracket as **close to the Air Bag** as possible.
- * The top of the Bracket will extend above the Vertical Frame.

Attach the Mounting Bracket to the Vertical Frame with 1-1/2" self-drilling screws.

e. **Repeat** steps b, c, and d for other Vertical Frame.

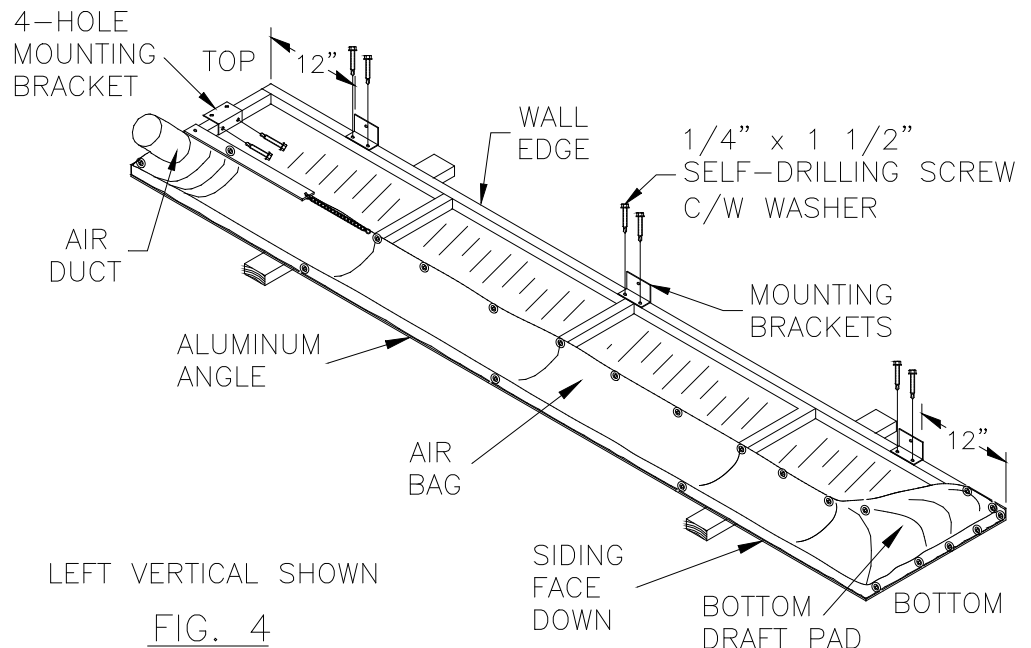
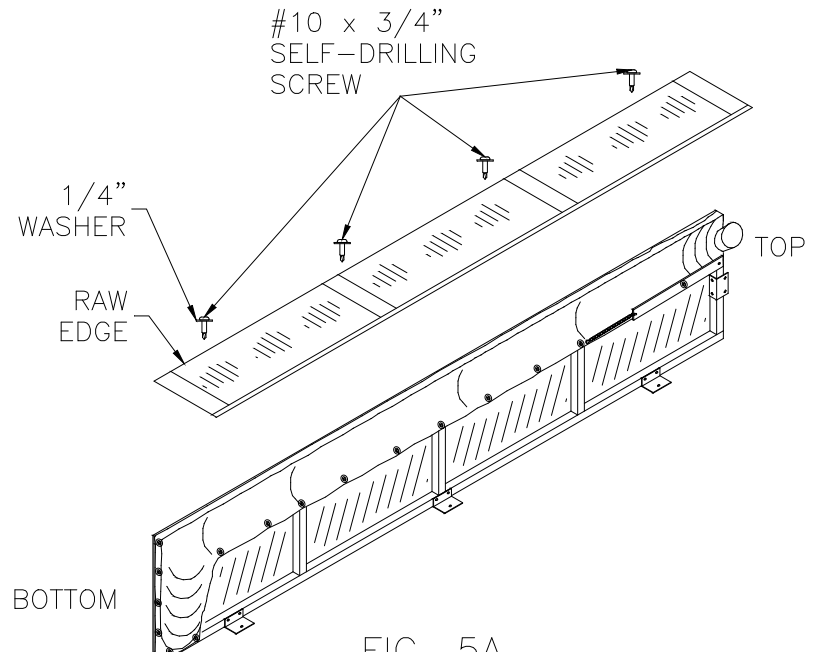

FIG. 4

5. Attach Vertical Storage Curtains to Vertical Frames

- a. **Remove Aluminum Angle** from front edge.
Rest Vertical Frame on wall edge and Mounting Brackets.
- b. **Determine left and right** Vertical Storage Curtains.
Raw edge attaches to Vertical Frame.
Place finished side to the outside.
Grommet is at the top, near leading edge.
- c. **Position and secure** Vertical Storage Curtain.
Place bottom of Vertical Storage Curtain flush with bottom of Vertical Frame (Figure 5a).
 - * **Raw edge flush** with edge.**Secure** with 3/4" self-drilling screw.
 - * Do not put screw through stay.**Spread rest of Vertical Storage Curtain** along Vertical Frame.
 - * Keep flush with edge, ensuring a tight fit.**Secure** Vertical Storage Curtain **between stays** with three (3) other evenly spaced 3/4" self-drilling screws.



6. Reattach Aluminum Angle to front edge of Vertical Storage Curtain

- a. **Place Aluminum Angle** along front edge of Vertical Frame (Figure 5b).
Match pre-drilled holes in angle and frame.
- b. **Starting at bottom**, insert 1-1/2" self-drilling screw and washer through pre-drilled hole.
Tighten.
- c. **Insert 1-1/2" self-drilling screws and washers** in remaining pre-drilled holes.
Tighten.

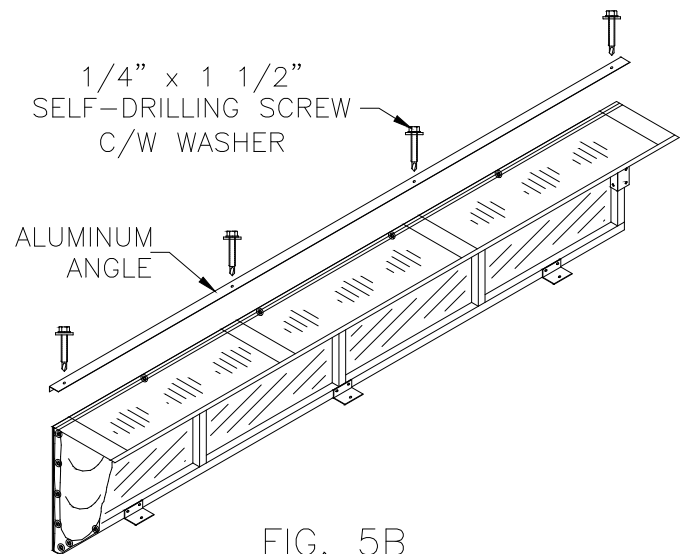

7. Remove Header Air Bag Assembly from Head Frame

- a. **Place Head Frame upside down** on clean, flat 2 x 4 supports (Figure 6).
Place top siding face down.

NOTE: DO NOT PUNCTURE OR SCRATCH EXTERIOR SIDING.

- b. **Remove Lag Bolts** from front of Head Frame.
- c. **Remove the Retraction Bungee Cord Assembly** from the Head Frame.
Remove and save screws from inside of back of Head Frame.
- d. **Slide the Header Air Bag Assembly off** of the Header Air Bag Brackets.
Slide toward back of Head Frame.
Do not drop Header Air Bag Assembly.
- e. **Place Header Air Bag Assembly** on a clean, flat surface.

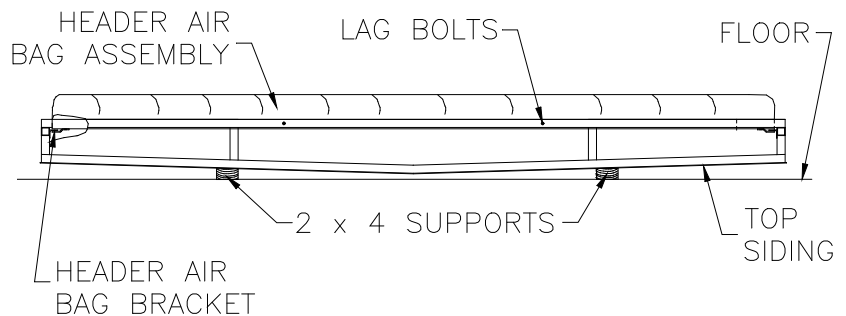

8. Prepare Head Frame

- a. **Position Mounting Brackets** on back of Head Frame (Figure 7).

Use **three (3) 3-hole** Mounting Brackets.

Measure 24" in from each end of Head Frame.

- * **Place** left and right Mounting Brackets **inside marks, along bottom** of Head Frame, corner flush to back of frame.

Place middle Mounting Bracket in **center**.

- b. **Attach** Mounting Brackets to Head Frame with 1-1/2" self-drilling screws and washers.
- c. **Move Head Frame** so the back sits on the floor.
- d. **Remove Aluminum Angle** from front edge. Set Aluminum Angle aside so it does not get damaged.

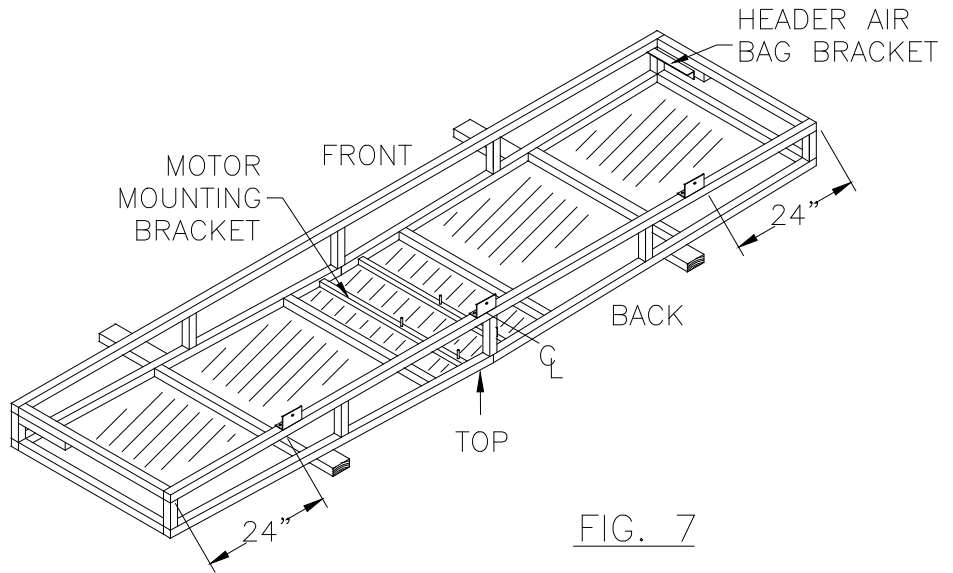

FIG. 7

9. Attach Vertical Frames to Wall

- a. **Position Vertical Frame** (Figure 8). Lift Vertical Frame on top of Protective Guard. Place wall edge flush to wall. Place exterior siding side flush to welded bracket on Protective Guard.
- b. **Make sure Vertical Frame is plumb, level, and square.**
- c. **Attach Vertical Frame to wall.** **Drill** holes through bottom Mounting Bracket only. **Insert** sleeve anchors or other appropriate mounting hardware into bottom Mounting Bracket holes.
- d. **Attach Vertical Frame to Protective Guard.** **Insert** 1-1/2" self-drilling screws and washers into holes in welded bracket on Protective Guards. **Secure.**
- e. **Repeat** for other Vertical Frame.

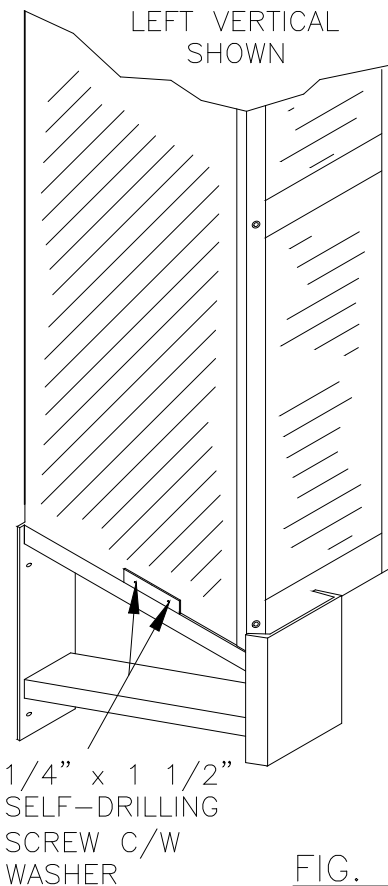

FIG. 8

10. Attach Head Frame to Vertical Frame

- a. Lift Head Frame onto Vertical Frames.
 - **USE APPROPRIATE, SAFE LIFTING METHOD.**
- b. Place Head Frame on Vertical Frames.

Set Head Frame on outside of left and right Angle Brackets (Figure 9a).

Position Head Frame flush to wall and flush to sides of Vertical Frames.

* The Head Frame will project beyond the front of the Vertical Frames by 10" (Standard).

- c. Attach Head Frame to Vertical Frames (Figure 9b).
Insert 1-1/2" self-drilling screws and washers through Angle Brackets
Tighten.

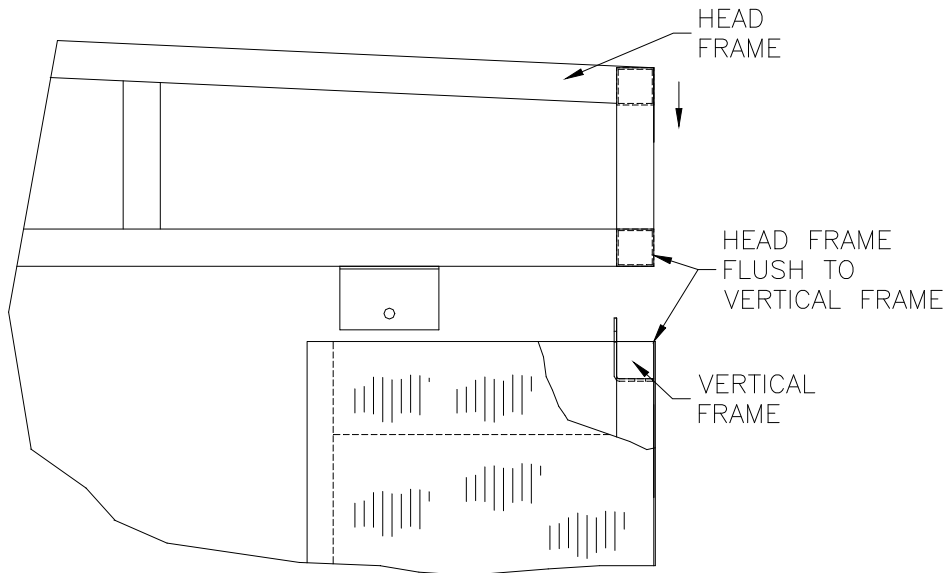

FIG. 9A

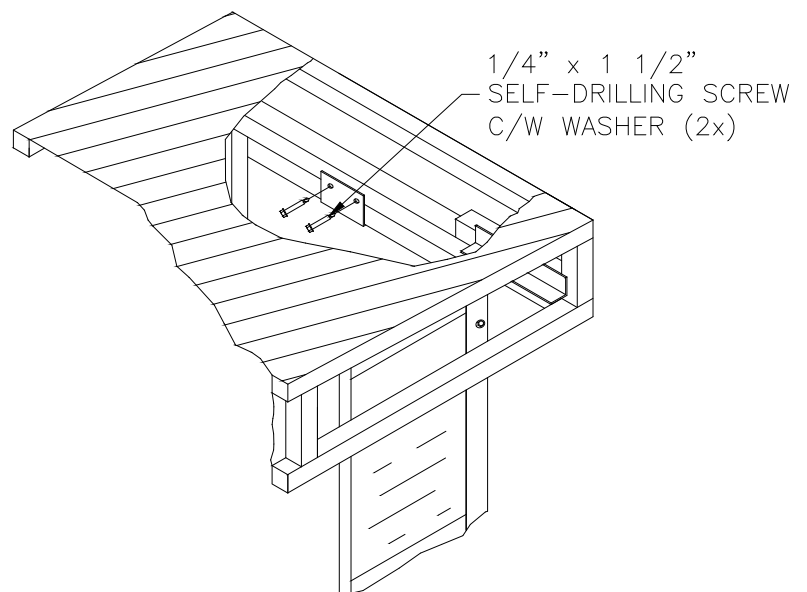

FIG. 9B

11. Attach Head Frame and Vertical Frame to Wall

- a. **Check entire shelter for plumb, level, and square**
(Figure 10a).
Shim where necessary.

NOTE: THIS SHELTER MUST BE PLUMB, LEVEL, AND SQUARE TO FUNCTION PROPERLY.

- b. **Attach Head Frame to wall.**
Drill holes through center Mounting Bracket (Figure 10b).
Insert sleeve anchor or other appropriate mounting hardware into holes.
Tighten.
Repeat for left and right Mounting Brackets.
- c. **Attach Vertical Frames to wall.**
Drill holes through remaining Mounting Brackets.
Insert sleeve anchor or other appropriate mounting hardware into holes.
Tighten.
Repeat for other Vertical Frame.

12. Reattach Header Air Bag Assembly

- a. **Insert Header Air Bag Assembly in Head Frame.**
Slide Head Curtain bracket into Head Frame Bracket.
Insert lag bolts and tighten.
Repeat for other side.

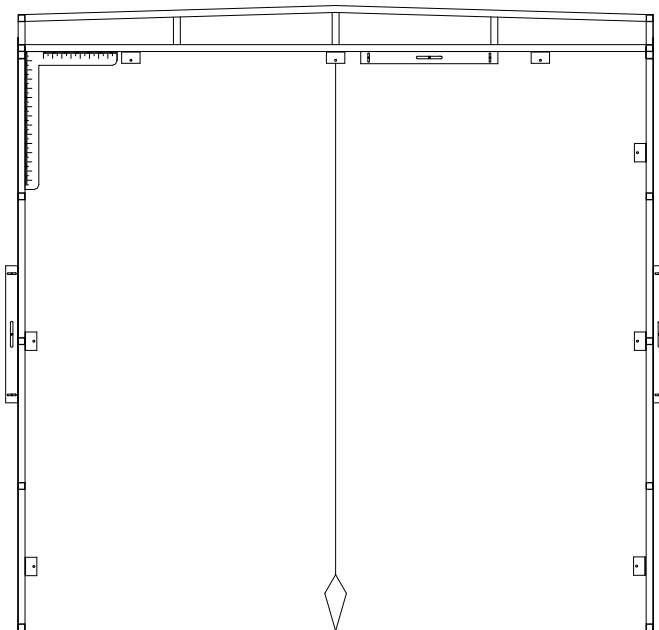

FIG. 10A

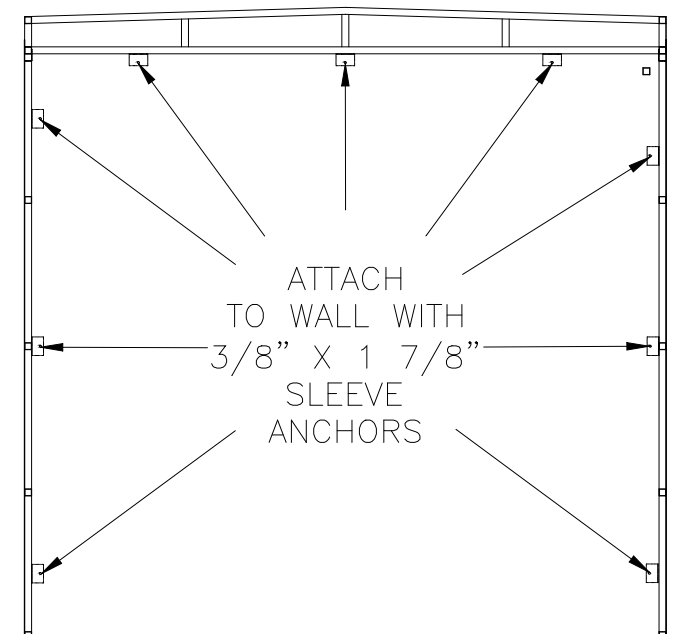

FIG. 10B

13. Connect Air Bags

- a. **Position Hose Clamps.**
Slide Hose Clamps around Throats
 (Figure 11a).
 - * Top of Vertical Air Bag.
 - * Top of Header Air Bag Assembly.
- b. **Insert Flexible Ducting into Throats.**
Grasp Hose Clamp around Throat.
Insert Flexible Ducting into Throat
 - * Place deep enough into Air Bag so that Flexible Ducting extends below top of Air Bag (Figure 11b).**Repeat** for other throat.
- c. **Tighten Hose Clamps on each Throat.**
Pull material up around Flexible Ducting.
 - * Make sure material will not block airflow.
 - * Carefully trim extra material, if needed.**Tighten Hose Clamps.**
Repeat for other throat.

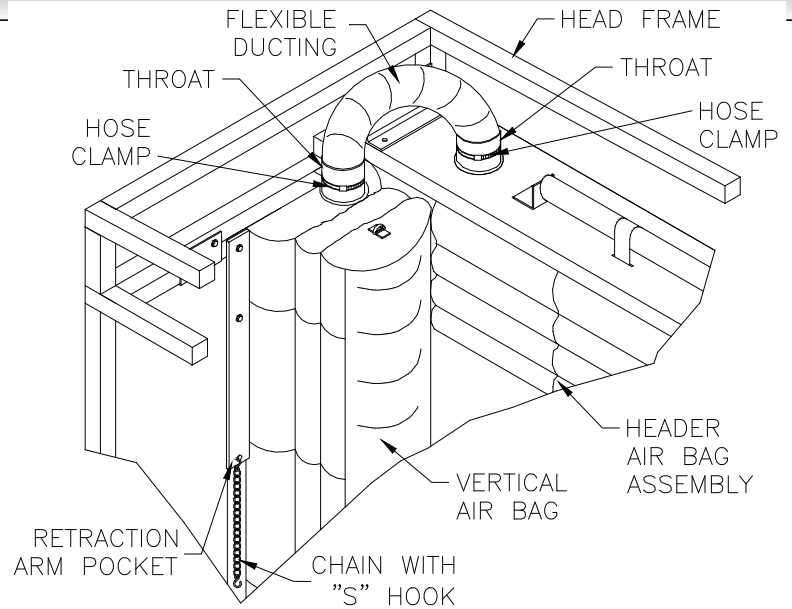

FIG. 11A

14. Connect Retraction Arm and Vertical Storage Curtain Support Strap

- a. **Connect Retraction Arm.**
Remove top screw on Retraction Arm
 (Figure 11a).
Loosen the bottom screw on Retraction Arm.
Rotate retraction arm 180° to upright position.
Insert a screw through hole at bottom and tighten.
Insert "S" hook at end of chain into "D" ring at leading edge of Vertical Bag (Figure 12a).
- b. **Attach Vertical Storage Curtain Support Strap.**
Insert "S" hook into grommet at top of Vertical Storage Curtain
 (Figure 12b).
Stretch Support Strap up to a Head Frame member.
Insert a screw through "S" hook and tighten.
- c. **Repeat Steps 13 and 14** for other side.

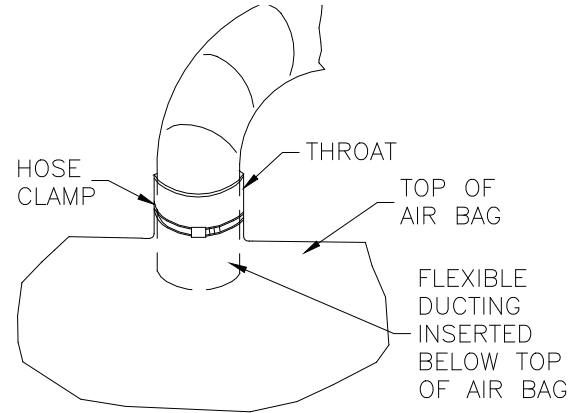

FIG. 11B

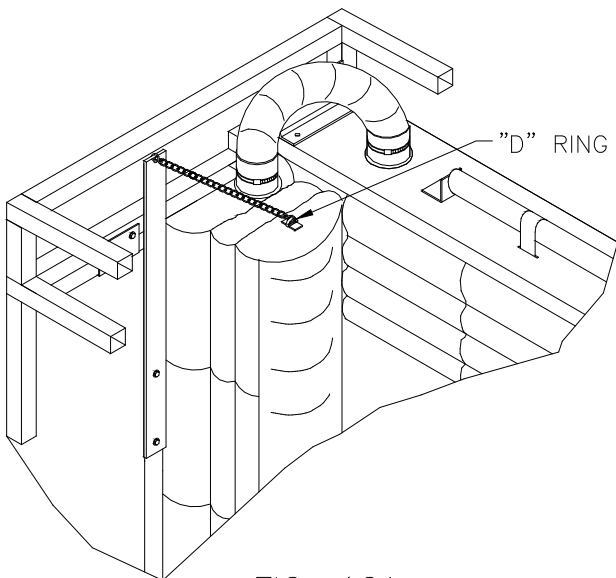

FIG. 12A

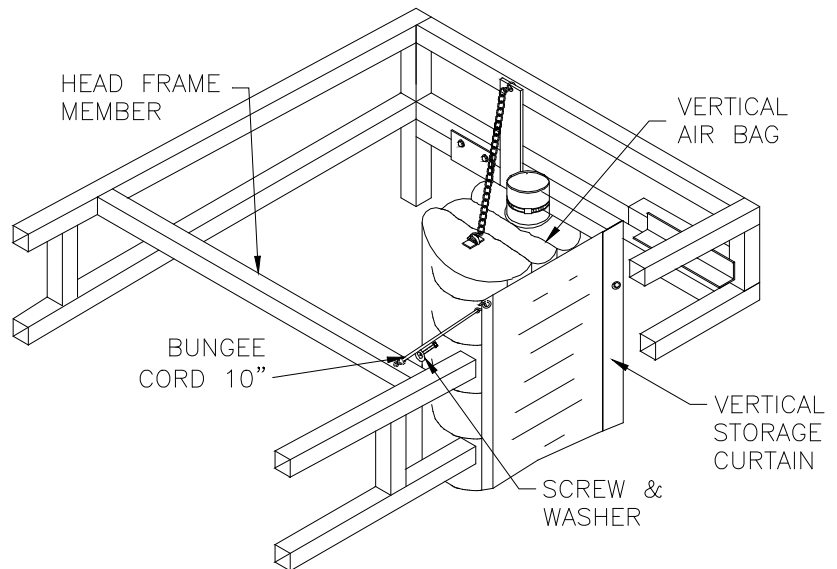

FIG. 12B

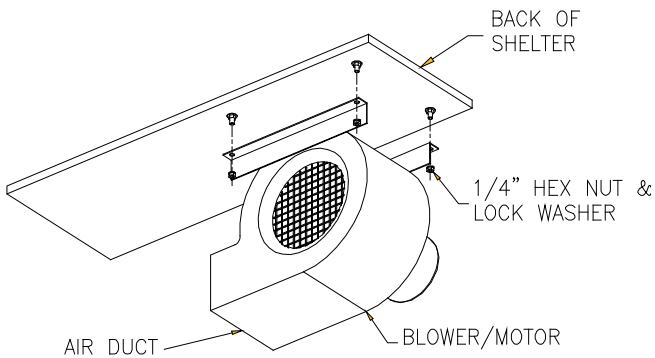

FIG. 13-A

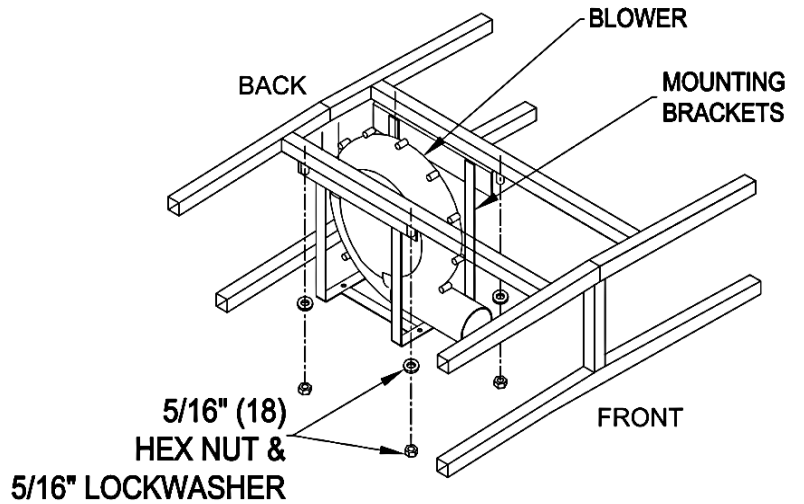

FIG. 13-B

15. Mount Motor/Blower

a. Mount Motor/Blower on Head Frame.

Remove nuts and lock washers from Motor/Blower bolts on Head Frame.

Mount Motor/Blower (Figure 13-A & 13-B).

- * Air duct should face the front of the shelter
- * Bolt bracket to header using 5/16" hex nut & lock washer supplied.

Replace lock washers and nuts on bolts.
Tighten.

b. Connect Header Air Bag to Motor/Blower.

Pull material over Blower Throat.

- * Make sure the material will not interfere with airflow.
- * Carefully trim excess material, if needed.

Secure into place with Blower Strap.

c. Reattach Retraction Bungee Cord Assembly to Head Frame (Figure 14).

Pull Bungee Cord Assembly to back of Head Frame.

Insert screws through Assembly into pre-drilled holes in back of Head Frame.

Tighten.

Repeat for other side.

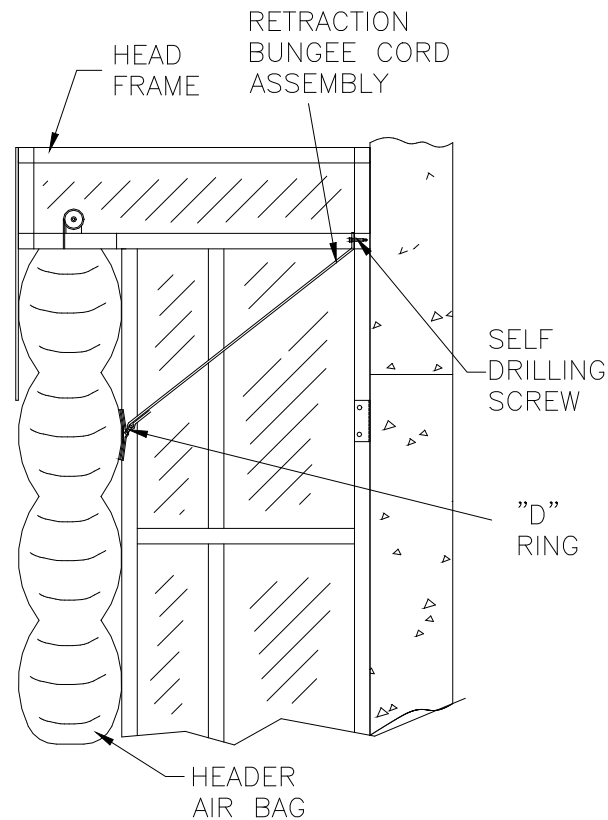

FIG. 14

16. Attach Head Storage Curtain to Head Frame

- a. **Position and secure Head Storage Curtain.**
Logo is on front of Head Storage Curtain.
Match top center of Head Storage Curtain with top center of Head Frame (Figure 15a).
 * Place raw edge flush to frame edge.
Secure with 3/4" self-drilling screw.
Spread rest of Head Storage Curtain along Head Frame and around sides.
 * Keep flush with edge, ensuring a tight fit.
Secure Head Storage Curtain to Head Frame.
 * Use evenly spaced 3/4" self-drilling screws on front and on sides.
- b. **Reattach Aluminum Angle** to front edge of Head Frame (Figure 15b).
Insert 1-1/2" self-drilling screws and washers into holes in Aluminum Angle.
Tighten.

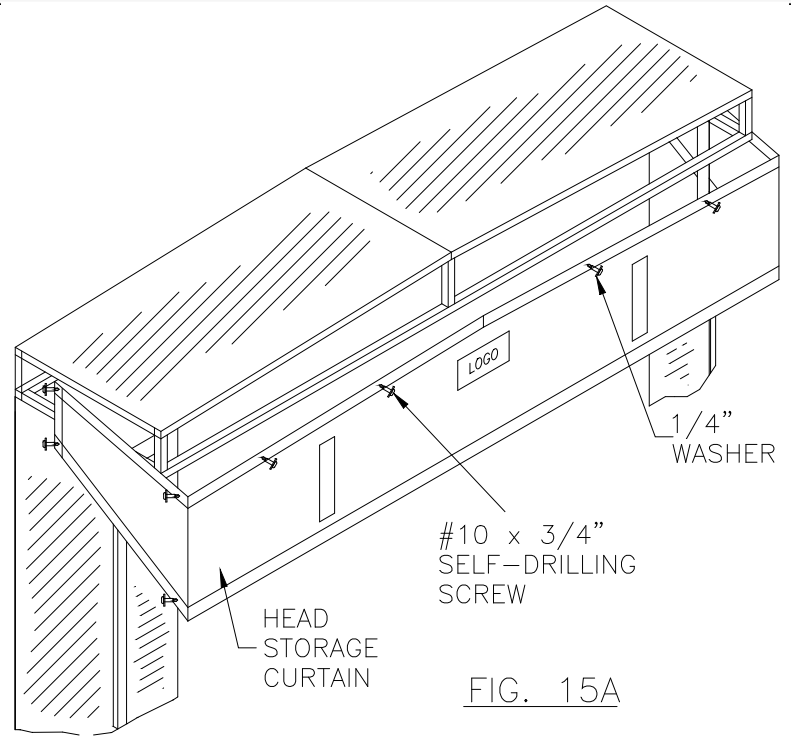

FIG. 15A

17. Caulk between Head Frame and Wall

- a. **A silicon or butyl rubber caulk** is recommended.
 NOTE: If mounting on a siding or pre-cast building, fill in gaps with styrofoam.
- b. **Caulk along:**
 Outside of Head Frame along Wall.
 Head Frame Aluminum Angle.
- c. **Fill in any remaining gaps** around unit as needed.

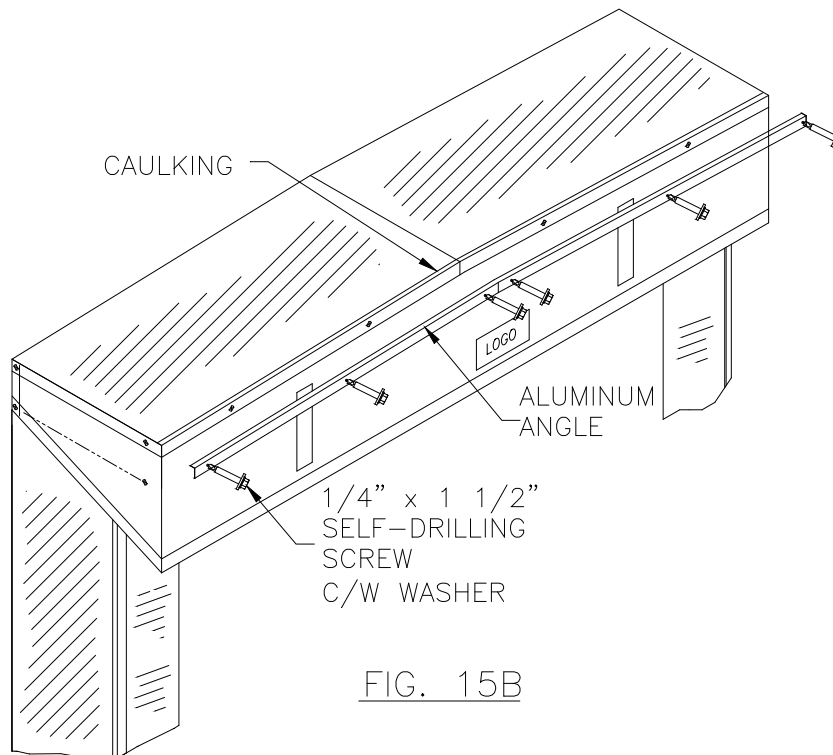

FIG. 15B

Series 0401A – STATIONARY INFLATABLE TRUCK SHELTER

ELECTRICAL INSTALLATION

READ ALL INSTRUCTIONS AND PURCHASE ORDER BEFORE INSTALLING ELECTRICAL COMPONENTS. A LICENSED ELECTRICIAN MUST PERFORM ELECTRICAL INSTALLATION AND HOOK UP. ELECTRICAL INSTALLATION MUST BE IN ACCORDANCE WITH ALL FEDERAL, STATE, AND LOCAL ELECTRICAL CODES AND REGULATIONS.

ALL HARDWARE AND ELECTRICAL SUPPLIES ARE PROVIDED BY THE CUSTOMER.

E1. Make Electrical Connections (Single Phase 115 Volt)

- a. **Mount ON/OFF switch.**
- b. **Or (OPTIONAL) Auto Switch Kit if ordered,** please see Auto Switch Kit instructions.
- c. **Switch Kit instructions.**
- d. **Install an outdoor receptacle** above the door opening on the outside.
- e. **Plug in the Motor/Blower.** Ensure Motor/Blower cable is properly tied back to avoid damage or injury.

115 VOLT	MODEL: KP-680
MOTOR POWER	680 WATTS
AMPS	4.5 A
WEIGHT	13 LBS
UNIT SIZE	16.2X14.2X11
ATTACHED CORD	6 FT, 3 PRONG

NOTE: THE MOTOR/BLOWER HAS A WIRE LEAD C/W 3 PRONG PLUG.

- **For units Outside North America** (1/2HP, 2850 rpm) motor requires wiring to motor junction box.
- **For 3-Phase power units** (208, 480, 575) motor requires wiring to motor junction box.

NOTE: THE MOTOR/BLOWER HAS A STICKER SHOWING THE WIRING DIAGRAM.

E2. Test Shelter

- a. **Make sure Air Bag travel is free** of objects or debris.
- b. **Flip ON/OFF switch to ON.**
Motor/Blower should come on immediately.
- c. **Observe inflation.**
Let unit fully inflate.
Make sure all air bags fully extend to dimension noted on Purchase Order.
- d. **Flip ON/OFF switch to OFF.**
Motor/Blower should turn off immediately.
- e. **Observe deflation.**
Vertical Air Bags should deflate and retract behind the Vertical Storage Curtains.
Header Air Bag should deflate and retract into the Header.

NOTE: DO NOT INFLATE UNIT WITHOUT A TRAILER IN DOOR OPENING UNLESS TESTING OR MAINTAINING SHELTER.

Series 0401A – STATIONARY INFLATABLE TRUCK SHELTER

OPERATING INSTRUCTIONS

PLEASE READ ALL OPERATING INSTRUCTIONS BEFORE USING THE SHELTER. PROPER EMPLOYEE TRAINING IN SAFETY AND OPERATING PROCEDURES IS ESSENTIAL TO SAFE AND CORRECT SHELTER OPERATION. IT IS THE CUSTOMER'S RESPONSIBILITY TO ENSURE THE SHELTER IS SAFE FOR EVERYONE USING IT. SUPER SEAL IS NOT RESPONSIBLE FOR ANY PRODUCT WEAR, PRODUCT FAILURE, PROPERTY DAMAGE, OR PERSONAL INJURY THAT MAY RESULT FROM IMPROPER SHELTER OPERATION.

OP1. Standard Operation

Back trailer into shelter, centered between Verticals.

If using Auto Switch Kit, please see Auto Switch Kit for Inflatable Products Operation Instructions.

Turn switch ON to inflate shelter.

Turn switch OFF to deflate shelter.

Remove trailer from shelter.

Repeat for every trailer.

OP2. Do not remove a trailer from an inflated shelter

Air Bags may get damaged.

Trailer may catch Air Bags and damage entire shelter.

Personal injury or mishap may occur at the door opening.

Series 0401A – STATIONARY INFLATABLE TRUCK SHELTER

OPTIONS INSTALLATION INSTRUCTIONS

ADDITIONAL OR DIFFERENT HARDWARE MAY BE PROVIDED OR REQUIRED BY OPTIONS. PLEASE SUBSTITUTE THE FOLLOWING INSTRUCTIONS FOR THE STANDARD SHELTER INSTRUCTIONS AS DIRECTED.

**STATIONARY VERTICAL 0401 PANELS
IN LIEU OF AIR BAGS**
or
**STATIONARY SUPERSNUG PANELS
IN LIEU OF AIR BAGS**

O1. Attach Vertical Panels to Vertical Frames

- a. **Remove Aluminum Angle** from front edge.
Rest Vertical Frame on wall edge and Mounting Brackets.
- b. **Determine left and right** Vertical Panels.
Raw edge attaches to Vertical Frame.
Yellow stripe appears at bottom and “Z” reinforcement appears at the top.
- c. **Position and secure** Vertical Panel.
Place bottom of Vertical Panel flush with bottom of Vertical Frame (Figure O1a).
 - * **Raw edge flush** with frame edge.
 - Secure at bottom** with #10” self-drilling screw and 1/4” washer.
 - * Do not put screw through stay.
 - Spread rest of Vertical Panel** along Vertical Frame.
 - * Keep flush with frame edge, ensuring a tight fit.
 - * Vertical Panel will be shorter than the Vertical Frame.
 - Secure** Vertical Panel between stays with three (3) other evenly spaced #10” self-drilling screws and 1/4” washers.

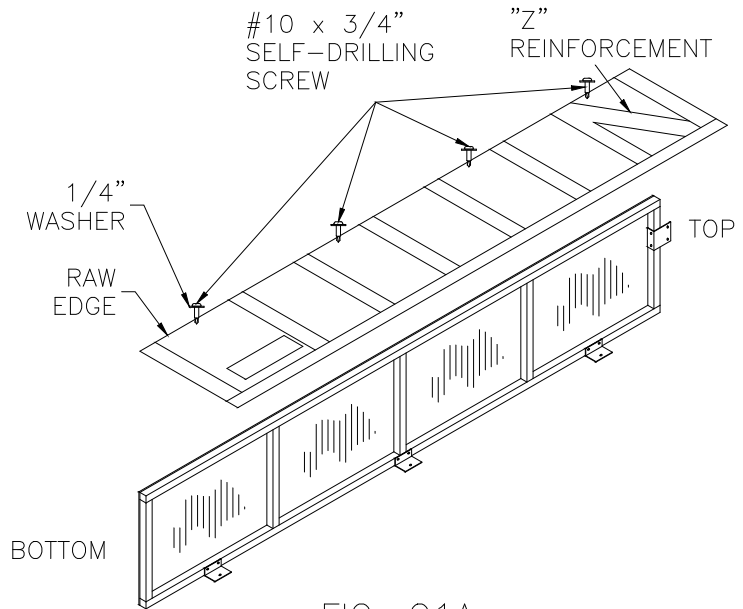

FIG. O1A

O2. Re-attach Aluminum Angle to Front Edge of Vertical Panel

- a. **Match** holes in Aluminum Angle with holes in Vertical Panel stays (Figure O1b).
- b. **Attach** to Vertical Frame using 1/4" self-drilling screws and 3/8" washers.

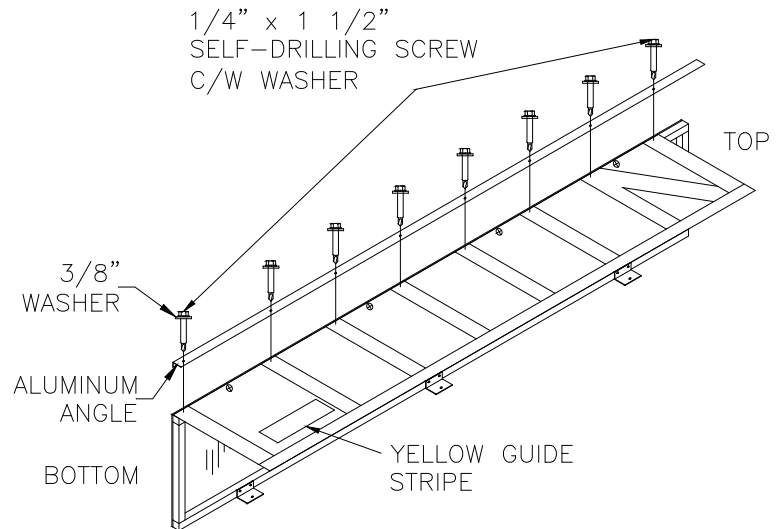

FIG. O1B

O3. Attach Wind Strap to Aluminum Angle.

- a. **Place** Wind Strap "S" hook at hole at top of Vertical Frame (Figure O1c).
- b. **Attach** "S" hook 1" down from top and 3/4" in from outside edge. Use 1/4" self-drilling screw and 3/8" washer.
- c. **Pull** Wind Strap down 36" along Aluminum Angle or until taut.
- d. **Attach** bottom "S" hook 3/4" in from outside edge. Use 1/4" self-drilling screw and 3/8" washer.
- e. **Repeat** Steps O1, O2, and O3 for other Vertical Frame.

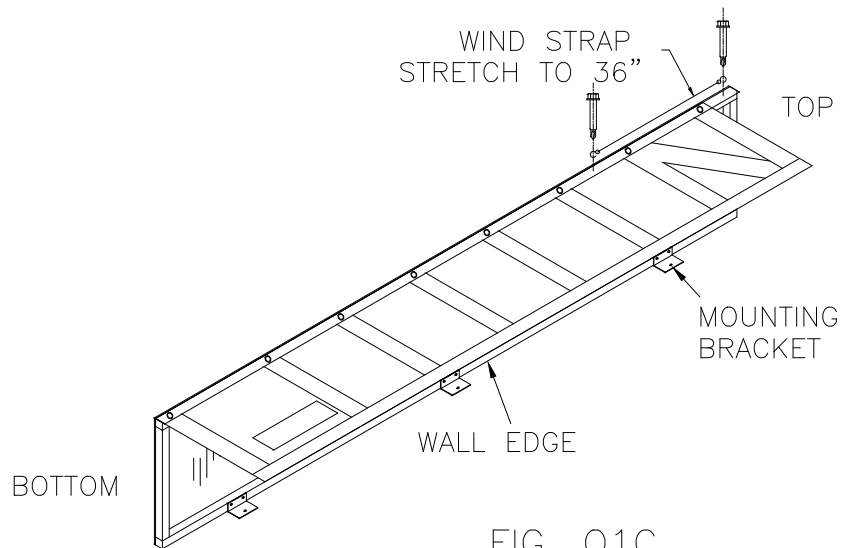

FIG. O1C

Series 0401A – STATIONARY INFLATABLE TRUCK SHELTER

TROUBLESHOOTING INSTRUCTIONS

PLEASE READ THIS GUIDE BEFORE CALLING YOUR SERVICE PROFESSIONAL. MAKE SURE THE SHELTER IS SAFE TO EXAMINE BEFORE STARTING ANY TROUBLESHOOTING. FOLLOW ALL WORKPLACE SAFETY PROCEDURES TO PREVENT INJURY TO SERVICE PERSONNEL, EMPLOYEES, AND THE PUBLIC.

T1. Air Bags do not seal against trailer

- a. Make sure trailer is centered between verticals.
- b. Make sure balloons fully extend after inflation.

T2. Air Bags do not fully inflate

- a. **Check air supply.**
Check Motor/Blower.

DANGER! DO NOT PLACE HANDS OR TOOLS IN BLOWER WHILE MOTOR IS RUNNING. SECURE WORK AREA. MAKE SURE MOTOR IS OFF WHILE WORKING INSIDE THE BLOWER.

- * Make sure Motor/Blower is properly wired.
- * Make sure Intake is clear.
- * Make sure Blower is clear.

Check Throats.

- * Make sure Throats are not blocked by too much fabric or by debris. Check:
 - Blower Throat;
 - Header Air Bag Throats; and
 - Vertical Air Bags Throats.

Check Flexible Ducting.

- * Make sure Flexible Ducting is installed deep enough into each Air Bag.

T3. Header Air Bag does not fully inflate

- a. **Check air supply** as directed in Step T2.
- b. **Check Header Air Bag Assembly.**
 Make sure **Retraction Spring Straps** are travelling straight and are not twisted.
 Make sure **Torsion Spring tension** is not too tight.

DANGER! TORSION SPRING IS NORMALLY UNDER HIGH TENSION. ALWAYS USE EXTREME CAUTION WHEN ADJUSTING TORSION SPRING TENSION.

- c. **Reduce Torsion Spring tension, if required.**
Work on end with Spring Tension Retaining Bolt (Figure T1).

Insert screwdriver into hole in small shaft.

Secure screwdriver.

Remove Spring Tension Retaining Bolt.

Slowly unwind tension from spring.

- * Use alternating screwdrivers.
- * Wind shaft in opposite direction noted on Shaft Winding Sticker.

Secure screwdriver.

Insert Spring Retaining Bolt.

Tighten.

- d. Make sure **Retraction Bungee Cord Assembly** is properly installed (See Installation Instruction Step 15).

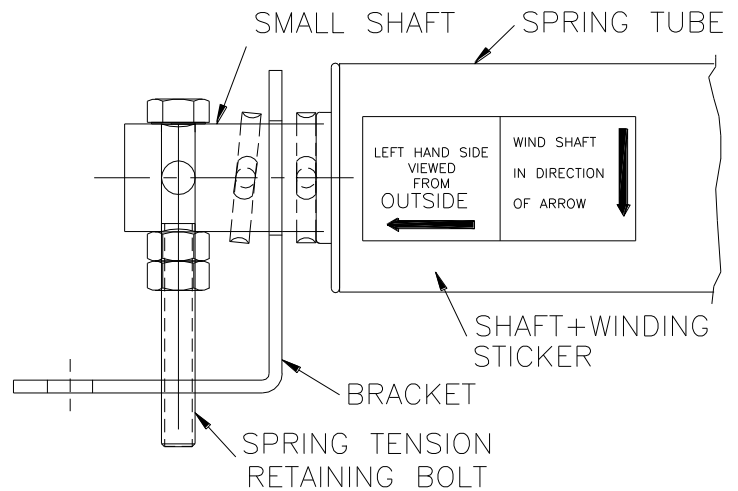

FIG. T1

T4. Vertical Air Bag does not fully inflate

- a. **Check air supply** as directed in Step T2.
- b. Make sure **Retraction Arm** is properly installed (See Installation Instruction Step 14).
- c. **Shake Vertical Air Bag.**
 Rope may be stuck or broken.
 Counterweight may be stuck.
- d. **Consult Factory** if problem cannot be solved.

T5. Air Bags do not fully retract after deflation

- a. **Make sure no obstructions or barriers** interfere with the Air Bags.
- b. Make sure **Retraction Arm** is properly installed on Vertical Air Bag (See Installation Instruction Step 14).
- c. Make sure **Retraction Bungee Cord Assembly** is properly installed On Header Air Bag (See Installation Instruction Step 15).